

Butterfly Valve, Welded Ends

- **Manufacturing standards:** Millimeter round tubes manufactured according to DIN-11850, SMS 3008 and ASTM A-270 - EN 10217-7
- **Grades:** Austenitic grades types 304-L, 316-L
- **Protection:** Polished or satin tubes are supplied with plastic coating
- **Finishes:** Finished with roughness according to standards on the surface and welding suitable for the food industry. We have pipes in matte and polished interior and/or exterior finishes.
- **Certificates:** We provide product certificates if required, according to the following standard: EN 10204/3.1.B or DIN 50049.
- **Dimensions:** Manufactured in diameters from 12 mm to 154 mm. Wall thicknesses from 1 to 2 mm

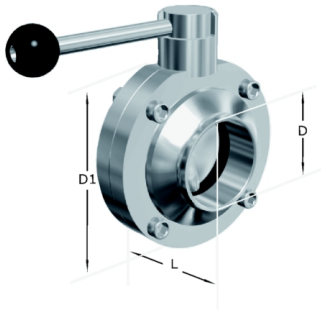

Technical information

Dimensiones									Calidades	
N W	A	B	C	D1	D2	D3	Peso	AISI-304	AISI-316	
					D					
25	40	107	90	26	31	87	1.3	x	x	
32	42	107	92	32	37	92	1.4	x	x	
40	50	137	94	38	43	97	1.5	x	x	
50	50	137	101	50	55	110	1.8	x	x	
65	50	137	110	66	72	127	2.2	x	x	
80	60	167	123	81	87	142	4	x	x	
100	64	167	134	100	106	162	4.8	*	x	
125	112	248	168	125	132	200	8.1	*	*	
150	124	248	183	150	157	230	10.3	*	*	