

Butterfly Valve, Nut-Nut

- **Manufacturing standards:** Millimeter round tubes manufactured according to DIN-11850, SMS 3008 and ASTM A-270 - EN 10217-7
- **Grades:** Austenitic grades types 304-L, 316-L
- **Protection:** Polished or satin tubes are supplied with plastic coating
- **Finishes:** Finished with roughness according to standards on the surface and welding suitable for the food industry. We have pipes in matte and polished interior and/or exterior finishes.
- **Certificates:** We provide product certificates if required, according to the following standard: EN 10204/3.1.B or DIN 50049.
- **Dimensions:** Manufactured in diameters from 12 mm to 154 mm. Wall thicknesses from 1 to 2 mm

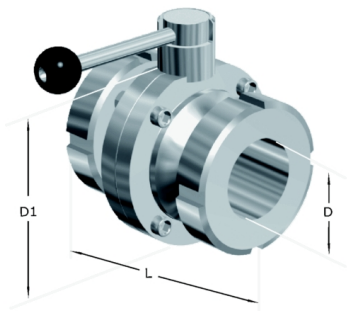

Technical information

Dimensiones	N W	A	B	C	D1	D3	Peso	Calidades	
								AISI-304	AISI-316
	25	84	107	90	26	87	2	*	x
	32	92	107	92	32	92	2.2	*	x
	40	102	137	94	38	97	2.6	*	x
	50	106	137	101	50	110	3.5	*	x
	65	114	137	110	66	127	4.3	*	x
	80	134	167	123	81	142	7.3	*	x
	100	152	167	134	100	162	9.9	*	x
	125	180	248	168	125	200	11.8	*	*
	150	198	248	183	150	230	15.2	*	*