

Equal Tee

Manufacturing Standards: DVGW round tubes manufactured according to DIN-1988/2463 EN 10312. Tubes with DVGW TS 225 authorization correspond to the requirements of the DVGW W 541 worksheet. **Certificates:** Standard stock lengths of 6 meters. Product certificates are provided, if required, according to the following standard: EN 10204/3.1.B or DIN 50049. **Grade:** Austenitic, series 304 - L, 316-L. **Dimensions:** Manufactured in diameters from 15 mm to 108 mm. Wall thickness of 1 to 2 mm. **Applications:** DVGW W 541 tubes are used for transport of chlorinated drinking water up to 2 mg / l in AISI-316 L grade water pipes. The AISI-304 L grade is used in compressed air systems.

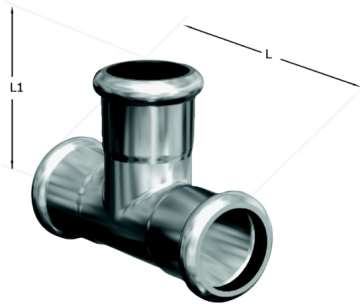

Technical information

DN	Dimensiones			Art.
	Tubo Ø	L	L1	
12	15	64	39	1002
15	18	68	41	1003
20	22	74	44	1004
25	28	84	50	1005
32	35	100	57	1006
40	42	114	65	1007
50	54	138	77	1008
65	76,1	230	110	1009
80	88,9	260	128	1010
100	108	310	153	1011