

Tees, ISO

Manufacturing Standards: ISO-1127-dimensional accessories manufactured for welding according to ISO DIN-2605/17457

Grade: Austenitic series 304-L, 316-L

Finishes: Standard finish 2B

Dimensions: Manufactured in diameters from 17.2 mm to 456.2 mm

Certificates: Product certificates provided, if required, according to the following standard: EN 10204/3.1.B or DIN 50049.

Tolerances: Allowable Differences in diameter and eccentricity + - 1.0% and thickness of + - 15%

Applications: Primarily used to construct pipes or tubes, as conductors of fluids (gases, liquids, slurries and solids in powder state).

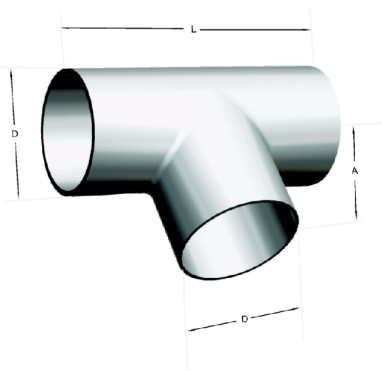

Technical information

DN	Ø	Dimensiones				Peso kgs	Calidades AISI	
	Nominal en Pulgadas	D	E	L	A		304-L	316-L
15	1/2"	21.3	2	51	25.5	0.05	x	x
20	3/4"	26.9	2	57	28.5	0.08	x	x
25	1"	33.7	2	76	38	0.12	x	x
32	1 1/4"	42.4	2	95	47.5	0.19	x	x
40	1 1/2"	48.3	2	114	57	0.25	x	x
50	2"	60.3	2	127	63.5	0.38	x	x
65	2 1/2"	76.1	2	152	76	0.6	x	x
80	3"	88.9	3	171	85.5	0.8	x	x
100	4"	114.3	3	210	105	1.3	x	x
125	5"	139.7	3	248	124	2.01	x	x
150	6"	168.3	3	286	143	3.2	x	x
200	8"	219.1	3	356	178	4.81	x	x
250	10"	273	3	432	216	7.33	x	x
300	12"	323.9	3	408	204	15.37	x	x

350	14"	355.6	4	558	279	18.55	x	x
400	16"	406.4	4	610	305	23.2	x	x
450	18"	457.2	4	686	343	29.37	x	x