

Tees, Metric

Manufacturing Standards: Welded millimetric components are manufactured according to DIN-2605/17457 standards.

Grade: Austenitic, series 304, 316, 304-L, 316-L.

Finishes: Standard finish 2B demand, satin or polished.

Dimensions: Manufactured in diameters from 18 mm to 506 mm.

Certificates: Product certificates provided, if required, according to the following standard: EN 10204/3.1.B or DIN 50049.

Image not found or type unknown

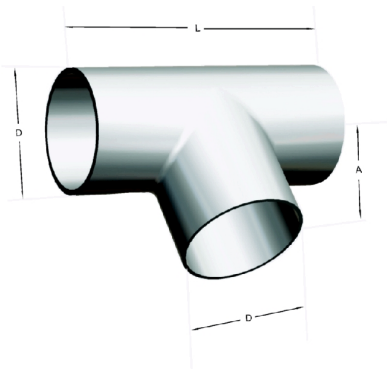

Technical information

DN	Dimensiones				Peso kgs	Calidades	
	D	E	A	L		AISI-304L	AISI-316L
15	18	1.5	25.5	51	0.04	x	x
15	20	1.5	25.5	51	0.04	x	x
20	23	1.5	28.5	57	0.05	x	x
20	25	1.5	28.5	57	0.06	x	x
25	28	1.5	38	76	0.09	x	x
25	30	1.5	38	76	0.1	x	x
25	33	1.5	38	76	0.11	x	x
32	38	1.5	47.5	95	0.16	x	x
40	43	1.5	47.5	95	0.17	x	x
50	50.8	1.5	57	114	0.21	x	x

50	53	1.5	57	114	0.25	x	x
50	63.5	1.5	63.5	127	0.3	x	x
65	73	1.5	76	152	0.45	x	x
65	76	1.5	76	152	0.5	x	x
80	84	2	85.5	171	0.8	x	x
100	104	2	105	210	1.2	x	x
125	129	2	124	248	1.85	x	x
150	154	2	143	286	2.64	x	x
200	204	2	178	356	3.92	x	x
254	254	2	216	432	7.23	x	x